

SofTILE KrosLOCK

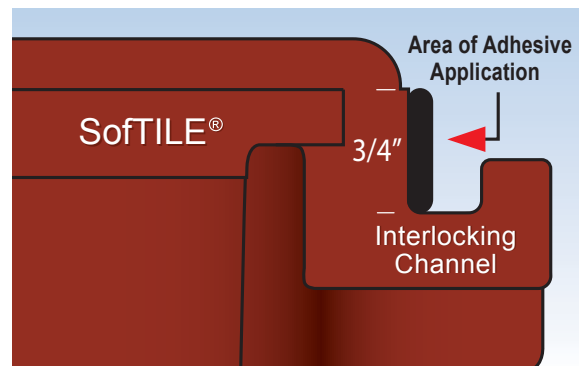

	PAGE
Introduction	1
Product Storage	
1. Adhesive.....	1
2. SofTILE.....	1
3. Geo-Textile.....	1
Tools & Consumables	
Recommended Tools & Consumables.....	1
Personal Protective Equipment.....	1
Optional Equipment.....	1
Site Survey	
1. Sub-Surface Drainage	
a) Naturally Draining Sub-Surface.....	2
b) Non Draining Sub-Surface.....	2
c) Solid Sub-Surface.....	2
d) Slope.....	2
2. Orientation	
a) Direct Sunlight.....	2
b) Continual Shade or Damp Areas.....	2
Site Preparation	2
Site Preparation - Pre Sub-Surface	
1. Remove all Sod and Topsoil.....	2
2. Install Water Collection System.....	2
Site Preparation - Sub-Surface	
1. Test Sub-Surface for Proper Slope.....	3
2. Test Sub-Surface for Proper Grade.....	3
3. Repair all Variations in Grade.....	3
4. Augering of Sites Will Disturb Existing Base Surfacing... 3	3
5. Curb Heights to be the Height of the Tile Surface or Higher... 3	3
6. Inspect Concrete Finish-No Cracks, Loose Material..... 3	3
7. Prepare Your Surfaces for Proper Adhesion	
a) Make sure Concrete and Asphalt Surfaces are Dry... 3	3
b) Confirm that the Concrete or Asphalt has Fully Aged/Cured..... 3	3
c) Mechanically Prepare the Area as Required..... 3	3
d) Acid Etch to Enhance Cleaning..... 4	4
e) Power Wash Sub-Surfaces That Are Dirty or Oily..... 4	4
Prior to the Installation of Tile	
1. Measure the Site and Record Dimensions.....	4
2. Check to Ensure Non-Encroachments Zones, Fall Heights, and Fall Zone Clearances.....	4
3. Confirm Adequate Materials to Complete Installation... 4	4
4. Atmospheric Temperature Above 40°F (5°C) & Rising... 4	4
5. Coefficient of Thermal Expansion..... 4	4
6. Watch for Variance in Color Tones..... 4	4
7. Installation of Geo-Textile..... 4	4
Confirm Site Size and Layout	
1. Multi-Colored Surface.....	5
2. Test Proper Measurements Prior to Commencing with Installation.....	5
3. Checking for Square.....	6

	PAGE
Installing Tiles	
Installing the Surface - Key Point Method.....	7
Install First Row in L-Shaped Pattern.....	7
Marking and Cutting Tiles	
Marking Posts.....	9
Cutting Tiles.....	10
a) Cut Hole Smaller or Tile Larger.....	11
b) Installing Cut Tiles.....	11
c) Volume Cutting.....	11
Adhearing Tiles	
Before Adhering Tile – Checklist.....	11
Adhesive Facts.....	11
Key Points.....	11
Preparing the Equipment.....	11
Application Methods	
Perimeter to Retaining Wall.....	12
a) Outdoor Installation to Curb.....	12
b) Outdoor Installation with Concrete or Asphalt Substrate - <i>Adhere to Base</i>	12
c) Outdoor Installation of Edge Tile - <i>Insufficient Support of Stanchions</i>	12
Perimeter with SofRAMP®.....	12
Perimeter to Topsoil/Sod.....	13
Playground Post Cuts.....	13
Application Nozzels.....	13
Adhesive Application Techniques.....	13
Key Points.....	13
Summary	14
Final Installation Details	
1. Remove Any Adhesive Spills	
a) “Smeared” Adhesive Spill.....	14
b) “Bead-Shaped” Adhesive Spill.....	14
2. Initial Appearance and Maintenance.....	14
3. Initial Odor.....	14
4. Sealant.....	14
Routine Maintenance	
1. Routine Maintenance Extends Life and Enhances Appearance.....	14
2. Sweeping.....	14
3. Vacuum.....	14
4. Water Hose.....	14
5. Cleaning Agents.....	14
Advance Maintenance	
1. Steam Vacuum.....	14
2. Power Washing.....	14
Checklists	15
Questions	15
Installation Inspection Form	16
Installation Inspection Form	18

Introduction

Whether you are a beginner or a professional installer of playground surfacing we highly recommend the reading of this Installation Manual and the viewing of our short video prior to beginning installation of your SofTILE® KrosLOCK safety surfacing system

Our video combines drawings, animation and video footage to encompass everything from the basic installation concept, to specific advanced techniques that are unique to our system.

By investing a few minutes in this manual and the video you will save valuable time on the project while avoiding some of the most common installation errors.

Should you have any questions or concerns please contact us at SofSURFACES at 1-800-263-2363.

Remember, the final quality of any playground surface is highly dependant on the techniques used by the installation crew.

Product Storage

1. Adhesive – Storage below 75°F (25°C)

Store all manufacturer supplied adhesives in a dry storage area. Shelf life 12 months.

2. SofTILE®

To ensure that the product is dry and above 40°F (5°C) at installation time, the tiles should be stored in a location with temperatures above 40°F (5°C) for at least 52 hours prior to the installation date. Tiles that will be stored for a long period of time prior to installation should be stored indoors. See further notes for storage during installation.

3. Geo-Textile (if required)

Store all manufacturer supplied Geo-Textile in a dry storage area.

Tools & Consumables

Like any job, your SofTILE® installation will go much smoother with the proper tools. The following list of tools and consumables are recommended for your upcoming project:

- Broom
- Leaf blower
- Aluminum straight edge 30 inch minimum - black lettering
- 24 inch squares – yellow or white lettering
- Measuring tape - Imperial measurement units (Tiles are made to Imperial measurements)
- Felt tip marker/paint tip marker to mark tiles for cutting (Sharpie™ – metallic silver or equal)
- Chalk line & refill bottle
- String line
- Heavy-duty auto lock cutter utility knife (Olfa LA-X™ or equal) & replacement blades (LBB ultramax™ or equal)

- Jig saw (Bausch or equal - minimum 5.5 amp or greater recommended)
- Jig saw blades (down-cutting blade; 10 teeth per inch)
 - Should be 1/4 inch shorter than the thickness of tile (in saw and when extended)
- Templates – for marking post holes for cutting
- Polyurethane Expansion Foam
- Duct or masking tape to protect adjacent items during adhesive application
- Disposable rags and/or paper towels (adhesive clean-up)
- Methyl Ethyl Ketone (MEK), also known as Methyl Acetone, and Acetone or other suitable solvents for clean up purposes
- Single barrel 14.4V power sausage caulking gun for 20 oz (by volume) tubes to dispense adhesive (Albion™ DL-45-T14E with Hytrel plastic piston) - Call regrading other manufacturers
 - SofSurfaces special nozzle for adhesive injection
 - Extra battery
- Single barrel sausage manual caulking gun for 20 oz (by volume) tubes to dispense adhesive (Albion™ DL-45-T18 with Hytrel plastic piston) usually included with shipment
 - Cone nozzles
 - SofSurfaces special nozzle for adhesive injection
- Thermometers – for measuring ambient and surface temperature
- U-Notched trowel with 1/4" or 3/8" deep grooves - standard ceramic tile adhesive spreading trowel, for perimeter tile to base adhesive spreading at installation edge

Personal Protective Equipment

- Disposable protective gloves (latex, nitrile or other) – for adhesive application
- Gloves (general work gloves)
- Safety glasses
- Hard hat
- Knee pads

Optional Equipment

- Vacuum cleaner
- Bent extension
- Hole saw – for scoring posts
- Weed sprayer – for moisture misting – low humidity days
- Bandsaw for volume cutting (scalloped blade)
- Hot box – for heating of adhesive
- Flex curve

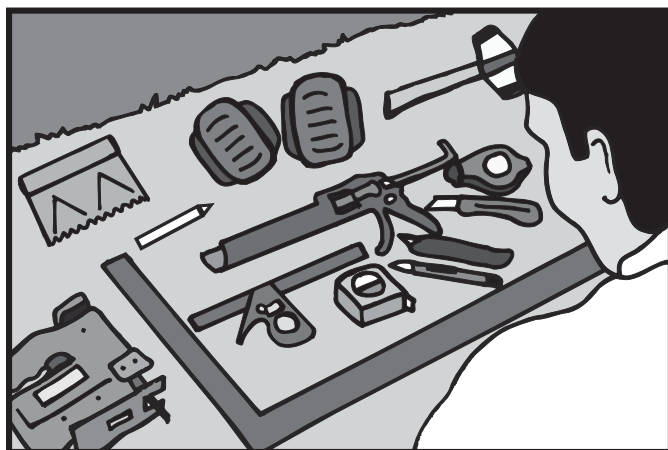

Site Survey

1. Sub-Surface Drainage

For both interior and exterior SofTILE® installations it is important that the sub-surface drains properly.

a) Naturally Draining Sub-Surface

If the installation site is elevated with natural drainage, and does not currently collect water, then additional storm water management may not be necessary.

b) Non Draining Sub-Surface

If the installation area is lower than the adjacent grades and tends to collect water, or if water puddles on the sub-surface, then a sub-surface water management system must be installed.

c) Solid Sub-Surfaces

If the sub-surface is solid (i.e. concrete or asphalt) and water collects on the surface deeper than 1/4" (0.25") in any area where the tiles are to be adhered to the base, these areas must be filled with patch materials recommended by the concrete or asphalt supplier. (See surface preparation section).

d) Slope

It is important that the sub surface be sloped a minimum of 1% toward the water collection drains.

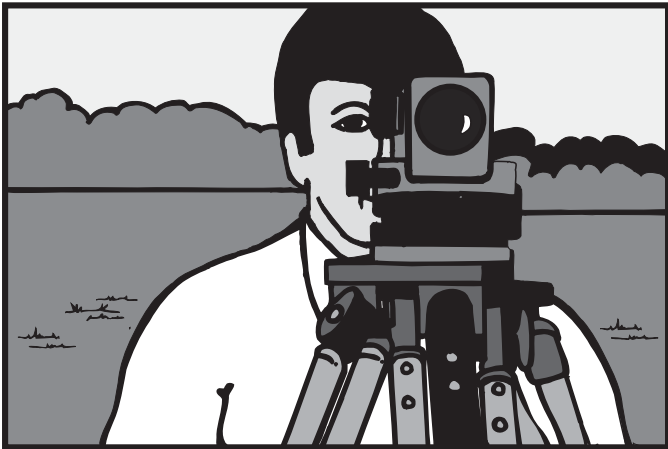

2. Orientation

Note: Although the final orientation of the installed surface may not be a matter of choice, some consideration should be given to the following items.

a) Direct Sunlight

SofTILE® is made from recycled rubber. Rubber absorbs heat from exposure to direct sunlight, rather than from exposure to atmospheric temperature. If the surface area is exposed to continual direct sunlight, design considerations should include lighter colors that reflect infrared light. (Lighter colored surface will provide a modest impact on surface temperatures).

Sun exposure is one of the potential safety threats on playgrounds. Any child, youth or adult can suffer from harmful UV rays penetrating their skin, or they can be burned by play equipment or rubber surfacing that has become too hot from sitting in direct sunlight. To avoid these risks, trees and other shading devices can be planned into the design of a playground area for sun protection or avoid play during times when UV rays are the strongest.

b) Continual Shade or Damp Areas

Installation sites with continual shade may remain damp for long

periods of time. During warmer temperatures damp areas may be subject to mold growth. In light of this, tile surfaces in shaded areas with the potential for mold growth should be cleaned periodically.

Site Preparation

The ideal sub-surface for the SofTILE® KrosLOCK system must be a firm and level surface with minimal undulations. For gluing to the surface it is critical that the surface is also clean, dry and free of oils.

- The recommended sub-surface is properly cured and installed concrete.
- Another alternative available is properly aged and prepared asphalt. To ensure proper adhesion the oils in the surface cannot be present and the asphalt surface strength needs to be ensured.
- A third alternative is a properly leveled and compacted sub base of 3 to 4 inches of (3/4 inch minus) aggregate of the correct size, type and consistency with a minimum properly leveled and compacted 1 inch layer of (1/4 inch minus) "chip & dust" or "granite screenings". Considerable care and skill is required to install a granular surface properly.

NOTE: This manual is not intended as an extensive guideline for installation of aggregate sub-surfaces.

Proper preparation of the sub-surface is critical to the long term success of your project. Due to the importance of proper sub-base preparation, SofSURFACES® has created a separate instructional manual specifically addressing the correct sub-surface preparation techniques required to obtain a surface suitable for a tile installation. Prior to beginning installation work please consult SofSURFACES® sub-surface preparation guide.

Site Preparation - Pre Sub-Surface

Note: Base preparation is normally covered under a separate contract from the SofTILE® installation however, the following information is provided as a brief guideline for those installations that do not have a properly prepared base.

1. Remove all Sod and Topsoil

Remove topsoil until solid, packed and stable sub-soil is visible and level.

2. Install Water Collection System

Carefully survey the site for drainage. Inspect the area after a rainstorm or test with local water supply. If this test results in the necessity to install a drainage collection system, then complete the following steps:

- a) Excavate trenches to contain perforated PVC pipe. Top of PVC pipe should be level with bottom of intended granular base. (PVC pipe is preferred over corrugated plastic drain tile because of the tendency for plastic drain tile to become crushed during it's life cycle).
- b) Install perforated PVC pipe with correct slope. Connect ends.
- c) Wrap perforated pipe with landscaping fabric.
- d) Back fill trenches with 3/4" clear stone. This 3/4" stone should wrap the drainage pipe to a diameter of approximately 12".
- e) Tie drainage system into existing storm sewer or ditch. Restore finished surfaces over trenched areas with appropriate ground cover (sod, etc.).

Note: A properly designed and installed water collection system is often overlooked during SoftTILE® site planning stages. Although the tiles are impervious, water will pass through the corners and seams of the SoftTILE® system, it is critical that a proper sub-surface drainage system be installed. Failure to do so could result in damage to the sub-surface and or SoftTILE® surface.



Site Preparation - Sub-Surface

For Packed Aggregate Sub-Surfaces see the Guideline Provided by SofSURFACES Entitled: Sub-surface Preparation Guide.

1. Test sub-surface for proper slope – should be minimum of 1%.

During heavy rains, water will collect on surfaces with slopes that are less than 1% or if the grade of the surface is not consistent. The surface should be able to accommodate 25 year storm water volume.

If water collects on any non-porous subsurface (asphalt or concrete), the adhesives can be affected over time. If significant water volumes cannot escape from the sub-surface and water backs up under the tiles, the hydraulic pressure could also result in a damaged installation.

To test the grade and drainage, flood the area with water and mark puddles with chalk. Puddles deeper than 1/4" and larger than 1" in diameter should be patched.

2. Test sub-surface for proper grade.

Frequently, sub-surface preparation is completed under separate contract to the SoftTILE® installation. When the subsurface is completed under another contract it may not be smooth enough for an immediate SoftTILE® installation because:

a) Aggregate sub-surfaces often become disturbed in the time between sub-surface installation and SoftTILE® installation.

b) The sub-surface contractor may not have taken the care and necessary steps to achieve a smooth and compacted surface.

Note: Any undulations in the sub-surface will be visually apparent in the finished SoftTILE® surface.



3. Repair or have repaired by the sub base installer all variations in grade that are greater than +/- 1/4" over 10' (in any direction)

a) Patch solid sub-surfaces with materials recommended by the concrete or asphalt manufacturer.

b) The site should have properly leveled and compacted minimum 1 inch layer of (1/4 inch minus) "chip & dust" or "granite screenings". This would be on top of a properly leveled and compacted sub base of 3 to 4 inches of (3/4 inch minus) aggregate of the correct size, type and consistency. If required more levelling and smoothing will be required or additional "chip & dust" added and compacted.

4. Augering of sites will disturb the existing base surfacing.

Where concrete/asphalt or granular surfaces have been removed or disturbed ensure that the areas are well compacted and sloped away from the posts. These areas should not be lower than the surrounding areas.

5. Curb heights are typically specified to be the height of the tile surface or higher.

An unlevel subsurface or curb is not cosmetically pleasing. Cutting the base of the tile to match the curb height is not recommended.

6. Inspect concrete finish to ensure there are no cracks and/or loose material. Concrete should have a light broom finish for best surface adhesion.

A heavy broom finish will result in a higher than normal adhesive usage. Ensure that there are no significant cracks and that the area is level.

Note: A properly prepared, cured and dry concrete or asphalt sub-surface is the ideal sub-surface for SoftTILE®.

Note: Clean the site well to ensure you are beginning with a clean level surface.

7. Preparing your surfaces for proper adhesion.

a) Concrete - It is important that the surface be completely dry to avoid adhesive failure. Since the perimeter tiles must be adhered to the concrete or asphalt sub-surface, it is important to ensure that it has cured sufficiently. Normally this is a minimum of 28 days for concrete. Allowing the concrete to sufficiently cure will ensure that most of the moisture has left the sub-surface. Less than 3lbs moisture per 1000 square feet is the ideal dryness level before applying adhesive. If the surface has a layer of "cement paste" it should be removed to ensure proper adhesion.

b) Asphalt may require longer curing time to allow the oils to dissipate. Some asphalt surfaces may have a significant amount of tars or oils and the adhesive should be tested to ensure adhesion.

After the adhesive has cured and if the tiles can be pulled up with asphalt or concrete attached to the glue, it is the base that has failed and not the adhesive. There are different qualities of concrete and asphalt.

c) Mechanically prepare the area as required. For concrete, the area to be glued should be mechanically prepared (sandblasted

or hand grinder) then cleaned to remove any dirt or dust. The same is for asphalt but a bond test should be done every time.

d) Acid etch to enhance cleaning (optional).

Note: Etching the concrete increases the adhesion by opening the surface pores of the concrete. Etching may be required on older surfaces with fuel, oil or other contamination.

Mix 25% Muriatic acid by volume to water (1 part Muriatic Acid to 3 parts water). Wash the entire area with this solution. A light broom scrub will be sufficient. After the complete area has been etched, carefully rinse the entire surface and allow adequate time for the concrete to completely dry.

e) Power wash sub-surfaces that are dirty or oily. Power washing is recommended on older concrete to properly clean the area. This is especially important if the concrete or asphalt has been contaminated with fuel, chemicals dirt etc. or the asphalt is newer.

Prior to the Installation of Tile

*SEE ADDENDUM FOR CHECK LIST

1. Measure the Site and Record Dimensions

2. Check with the equipment installer and customer to ensure non-encroachment zones (usually 6 ft beyond fall zone), fall heights (usually based on deck height or overhead equipment) and the fall zone clearances (meet local minimum requirements (usually minimum 6 ft or further for slide exits and for swings double the height). This is important in ensuring correct tile thicknesses are used to meet the local standards.

3. Confirm Adequate Materials to Complete the Installation

It is important to have enough products to complete the entire installation in a single installation session for the following reasons:

Note: During the quoting and material calculation process variance in tile dimension will have been taken into consideration when calculating tile quantities.

a) SofTILE® Plus and SofTILE® Premium, like new wood, concrete, asphalt or painted surfaces will change color with exposure to UV. This change is not as noticeable when all of the installed tiles change color at the same time. However, like installing a new piece of wood beside an old one, there will be a noticeable difference in the color tone of tiles installed at separate times.

b) Installing all tiles in one session ensures similarity in installation conditions and efficiency.

4. Atmospheric Temperature Above 40°F (5°C) and Rising

Atmospheric temperatures should be above 40°F (5°C) for at least 24 hours and preferably climbing. Viscosity, work life and final cure time of the adhesive will vary dramatically with temperature. Tile installation is not recommended if/when temperatures are expected to remain below 45°F (7.2°C) for an extended period of time.

5. Coefficient of Thermal Expansion

SofTILE® is manufactured from a combination of recycled rubber material and polyurethane binding resins. The high composition of rubber based materials make the product susceptible to heat related expansion and contraction. On hot sunny days the following guidelines should be carefully followed to minimize the impact of heat related expansion and contraction on the final installation.

- Keep the tiles stacked, covered and out of direct sunlight prior to installation. Remove tiles from the pallet only as they are needed. By keeping the tiles stacked, the insulating properties of the tile can be utilized by keeping the lower rows of tiles cool.
- Plan to begin your installation as early as possible while temperatures are cooler.
- Plan to apply adhesive during the earlier part of the day before the tile expand too much and end at least 6 hours before the sun begins to set.
- When the temperatures become such that the increase in tile size is preventing proper alignment of the seams, **STOP**. Spend the balance of the day making tile cuts for your perimeter and equipment posts.
- Many installers are installing during the night to minimize heat-related expansion.

6. Watch for Variance in Color Tones

SofTILE® Plus may have a slight variance in color tone from tile to tile. This is due to the recycled nature of the raw materials used in the production of rubber safety tiles. Visual effects of color variation can be minimized by placing these tiles in a less visible area such as under play decks.

SofTILE® Premium may also have a temporary color change due to the effects of UV on the thin layer of binder on the top of the EPDM or wear course. This thin layer will be influenced by UV which will appear to yellow or discolor the top surface. This thin layer will then begin to dissipate exposing the original color of the EPDM granules. These changes range in time, but we have found that in a period of 6 weeks to 3 months, you should have your original color back in which it will stay constant with proper maintenance for the life of the product. You do not notice this color alteration in the darker colored EPDM's, but you will in the lighter and brighter colors, such as blue, grey and beige.

7. Installation of Geo-Textile

Should the sub-base be compacted granular the surface will require a covering of geo-textile. A geo-textile is a permeable polymeric textile, either non-woven, knitted or woven material used in direct contact with the ground. This is required to pro-

test the migration of granular particles into the tile pedestals or settling of tile into the granular sub base. It is recommended that the geo-textile be at least "slippery" on one side. A suitable product would be Linq 200 or equivalent. Overlap the joints by at least 12". Continuously seal joints with polyurethane adhesive (same material used for tile to tile and tile to base adhesive). See our Sub-surface Preparation Guide for further details.



Confirm Site Size and Layout

When preparing for your initial site layout there are some important factors to take into consideration.

First, each SofTILE® KrosLOCK piece is manufactured to a dimension of 23 7/8 inches square with a manufacturing tolerance of plus or minus 1/8th inch.

Second, it is unlikely that your site is perfectly square or exactly as shown in the drawings.

When the site is curbed or recessed the rule of thumb is to plan on beginning and ending with a cut piece of tile. By planning to begin and end with a cut of at least 10 inches you will be assured of a visually proportionate site.

1. Multi-Colored Surface

Note: A shop drawing of the installation should accompany multiple colored SofTILE® installations with surface patterns. Confirm the shop drawing is accurate to actual site measurements and customers expectations prior to commencing installation.

2. Take Proper Measurements Prior to Commencing with Installation

Since SofTILE® dimensions can vary by +/- 1/8 inch it is very important to connect a row of tiles and take the exact measurement of the entire row prior to beginning installation. The theoretical length of 15 tiles should be 30 feet however the actual length may be slightly shorter.

**In Figures 1 through 4 we have used a site dimension of 30' by 30'. We used a sample dimension of 29'11" for the row of connected tiles.*

Note: To ensure a visually proportionate site, lay the surface out with equal dimension cuts on all four sides of the site. In most instances, when ramp edging is not used, plan on beginning and ending with cut tiles of roughly equal dimensions. For visual purposes cut tiles should be a minimum of 10 inches.

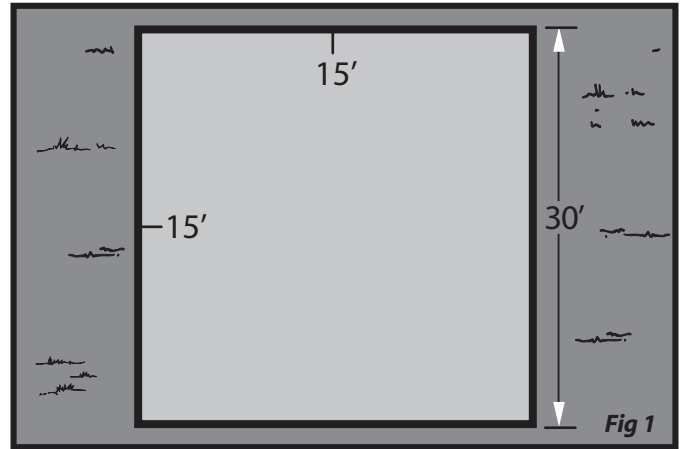

a) Measure and mark the center point on both the length and width of the site (Fig 1 - Overhead View).

b) Given SofTILE® manufacturing tolerance of plus minus 1/8", begin by obtaining an accurate measurement of a row of tiles. Lock together a row of tiles equal to the length and width of the site and measure the dimension (Fig 2). We have used a site dimension of 30X30.

Using this example the theoretical length of a row of 15 tiles should be 30 feet however the actual length could be shorter.

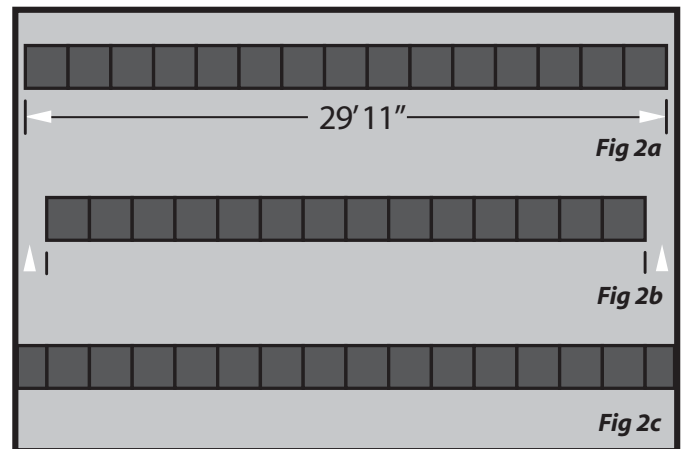

c) Using both the measurement from the halfway point to the perimeter and the measurement of the row of tiles you will be able to determine the size of the perimeter cuts. In our example the halfway point is 15' and the measurement of the row of tiles at the halfway point measures 14' 11 1/2 inches. Installing the full row of 15 tiles without calculating the cuts would leave us with a 1/2" gap on each side of our site (Fig 2a). To avoid this we will be centering 14 tiles which will leave us with a 1 1/2" gap on each side of the site (Fig 2b). By increasing the perimeter cuts from 1/2" to 1 1/2" we create a more visually attractive installation (Fig 2c).

Once the size of the outside perimeter cuts have been determined we are ready to string our lines which will be the basis for the beginning of the installation.

d) String a line parallel to the retainer. The distance between the retainer and the first string line should be equal to the size of the perimeter cuts. Based on our example this measurement is 1'1/2".

e) String a second line along the adjacent retainer forming an "L" shaped string line (Fig 3).

Note: For ease of installation install the field of tiles first leaving the outside perimeter cuts until last.

Now that the approximate size of the outside perimeter cuts have been determined, we are ready to string our lines which will be the basis for the beginning of the installation.

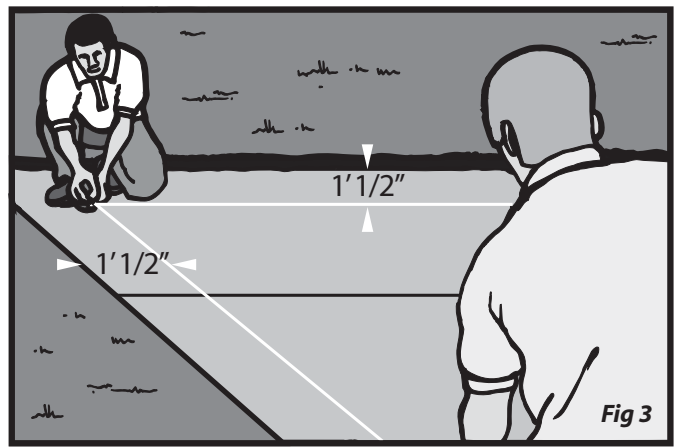

3. Checking for Square

Note: Prior to beginning installation it is important to ensure that the string line is square. Ensuring that the string line is square will provide a smooth and neat installation. In order to check for square we will be using what is often referred to as the "three-four-five" (or "six-eight-ten") method.

a) Measure 3 feet (or 6 feet) down one side of the string line and make a mark (Fig 4a - Overhead View - Line a-b).

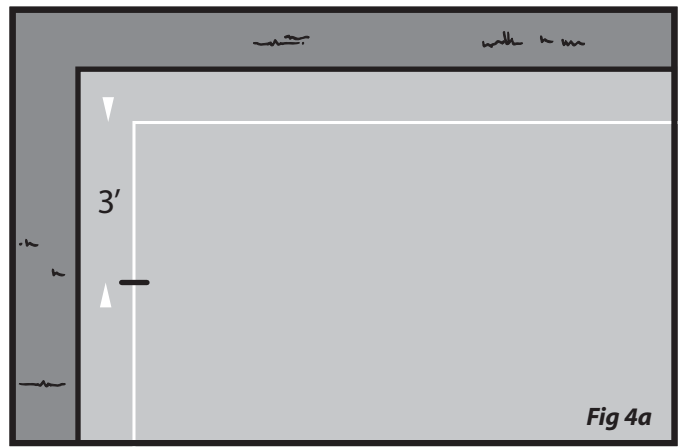

b) Measure 4 feet (or 8 feet) down the perpendicular string line and make a mark (Fig 4b - Line a-c).

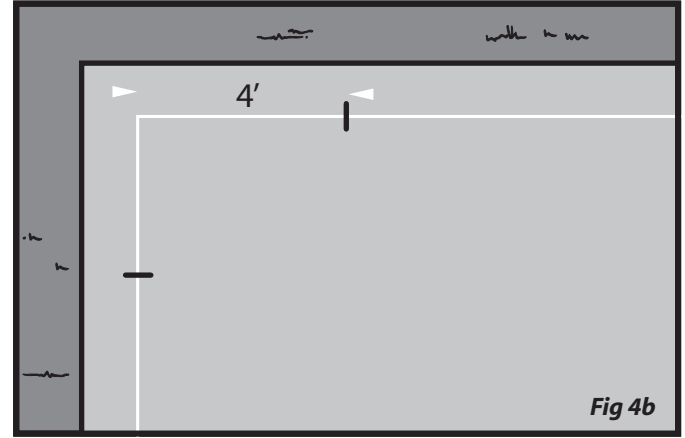

c) Measure the distance between the two marks at b and c. If the corner angle is square (90 degrees) the measurement between b and c is 5 feet (or 10 feet) (Fig 4c).

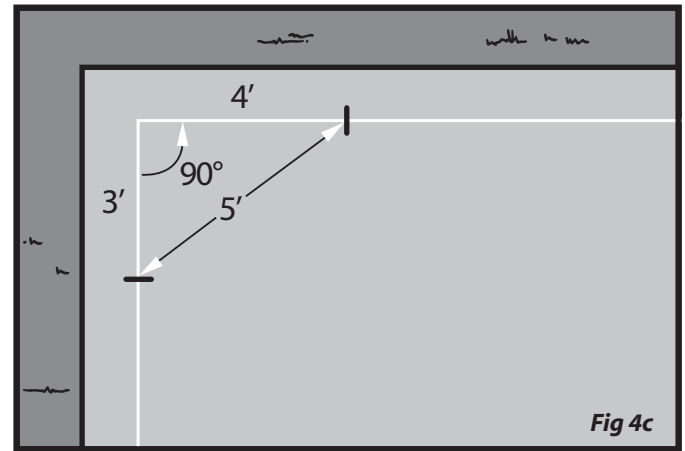

d) If the measurement of the line between b and c is more or less than 5 feet (or 10 feet), your lines are not in square and you will need to move one or both of the lines in or out until you reach the 5 foot (or 10 foot) measurement (Fig 4 d). The decision on which way to move your lines will depend on the visual effect it will have on the perimeter cuts. The general rule of thumb is to designate the least visual side of your playground for the majority of any uneven cuts.

Note: These instructions assume the adjacent walls and support structures are square. In the event non-square walls result in very thin cut-strips at the edge of the layout, move entire layout in a direction that allows cut pieces to be a minimum (cosmetically and structurally) acceptable size. The minimum acceptable size is 6 inches (2 stanchions).

Installing tiles on a site that is grossly out of square is beyond the scope of this installation guide. If you discover that your site is grossly out of square STOP and confirm site layout. Consult the customer or contractor to discuss options and if necessary consult an installation professional or contact SofSurfaces®.

NOTE: For best results the string line is installed to be just slightly higher than the thickness of the tile. This ensures the string is always visible and the tile can be aligned to the string or used as a measuring point. A chalk line only works as a point of reference until you cover it with the tiles.

Installing Tiles

Installing the Surface

SofSURFACES® latest installation techniques have been designed so that the adhesion process takes place after all of the tiles have been installed, locked in place and properly aligned and tightly fitted. By adhering the tiles after installation you are assured of a neater and more secure installation.

KEY POINT METHOD

Our unique interlocking system was designed for ease of installation, however, the process can be challenging if the correct techniques are not used. To maximize speed and efficiency install all KrosLOCK tiles in the following manner.

- Hold your tile at a 90 degree angle to the tile in front of it
- Slide outer lock over inner lock and set down
- This has secured three of the four locks on two sides of the tile
- Secure the final lock by lifting the adjacent tile
- Once all four locks have been secured, align the seams with all of the adjacent seams
- 'Kick' the tiles tight or snug

For sites smaller than 3000 square feet the chalk or string lines can be placed in the position as detailed above. However if the site is larger the location for lines when possible should be as close to the center of your site as possible (it is easier to maintain straight lines if posts aren't in the way of your initial tile layout). For larger sites the installations should be installed in quadrants, always working out from the original chalk or string line.

a) Using the KEY POINT METHOD above, install the first row of tiles (approx. 8 to 10 tile) along the string line. The edge of the top bevel of the tile should align with the string line (Fig 5 a).



As the tiles are being installed each tile will need to be fitted as tightly as possible to the adjacent tile. This is normally done by using a rubber mallet or the heel of your foot to "kick" the tiles tight or snug.

Note: If physical force does not position the tile properly, rotating the tile into alternate positions will in most cases ensure a proper fit.

Install First Row in L-Shape Pattern

b) Install the second row of tiles along the second string line forming an "L" shaped installation (Fig 5b).

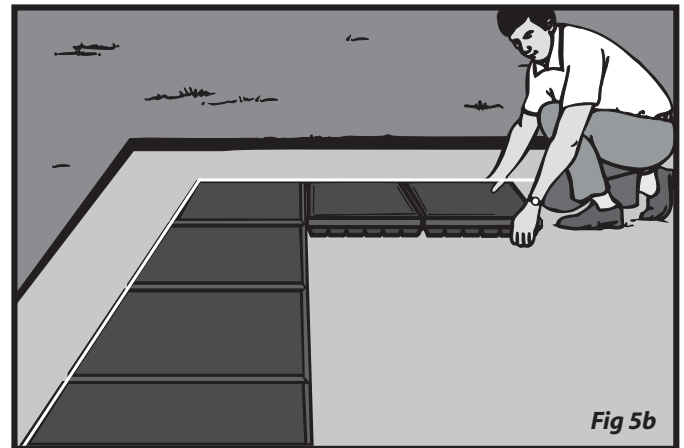

Continue to install tiles inside the L-shape. Be sure to use the "kicking" technique on each row installed, forcing each row against itself as well as against the adjacent row of tiles (Fig 5 c).

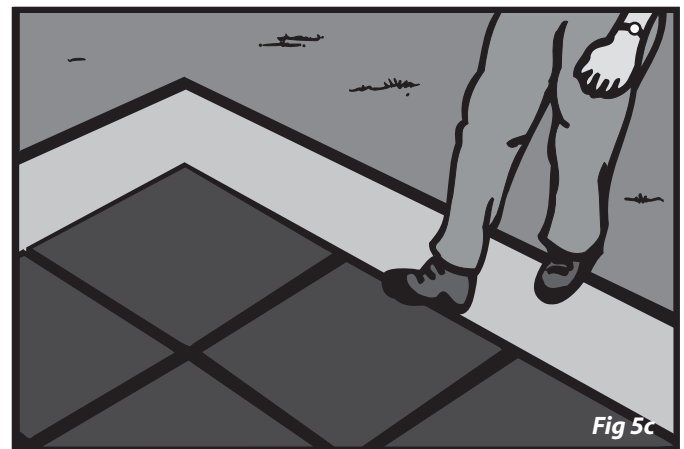

Note: Attention must be given to the amount of force used to align the tiles. Too much force will put the installation out of alignment.

Continue filling in the field of the project using the KEY POINT METHOD and following the "L" shaped configuration.

Note: For ease of installation, leave all cuts until last.

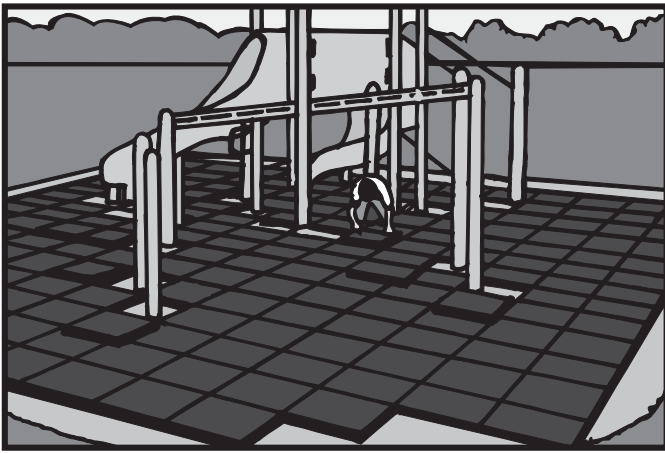

Marking and Cutting Tiles

Note: It is imperative that tile are in their correct position, fit together tight and lines are straight before tile measuring and cutting begins.

Start to measure, mark and cut from the tile which lies in the direction of your string line when ever possible and work your way out from those starting points (**keyline**). Be sure to install each tile as it is cut, this will ensure a proper fit for the next cut tile. When these cut tile are installed, the seams need to match neighboring seams. It is critical that as you move through your cut tiles that the seams match the adjacent tile.

GOAL – make edge cut to post or site curbs as tight as possible, to ensure a cosmetically pleasing finish.

When marking and cutting edge or perimeter tile, be sure to cut the tile larger by 1/8 to a 1/4 inch.

When marking and then cutting around the post, be sure to cut the hole 1/8 to a 1/4 inch smaller than the pole circumference.

Perimeter Marking

Mark any cuts for the perimeter tile pieces in the following manner:

1. With a 24 inch square, begin on the edge of the perimeter void where the tile needs to be placed and take a measurement from the edge of the perimeter to the edge of the last placed full tile. Transfer this measurement onto the tile that has been selected to be cut (*Fig 6a - Overhead View*).

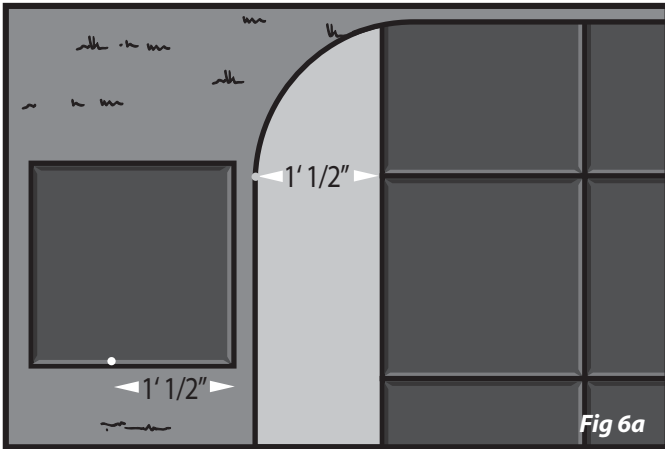

2. Move the 24 inch square or the tape measure approximately 3 inches across the void where the tile will be placed and take a second measurement. Move the same distance across your tile to be cut and transfer the second measurement onto the tile (*Fig 6b*).

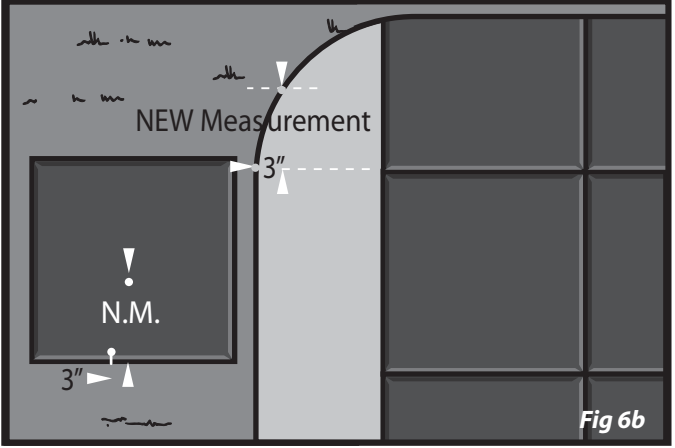

Note: Continue this process until enough references points have been transferred onto the tile. Straight regular cuts may only require two measurements per tile however irregular perimeters such as circles will require measurements in 2 or 3 inch increments across the tile. You can slide the square along the curve and get a reading of 'a and b' to pin point any location along the curve (*Fig 6c*).

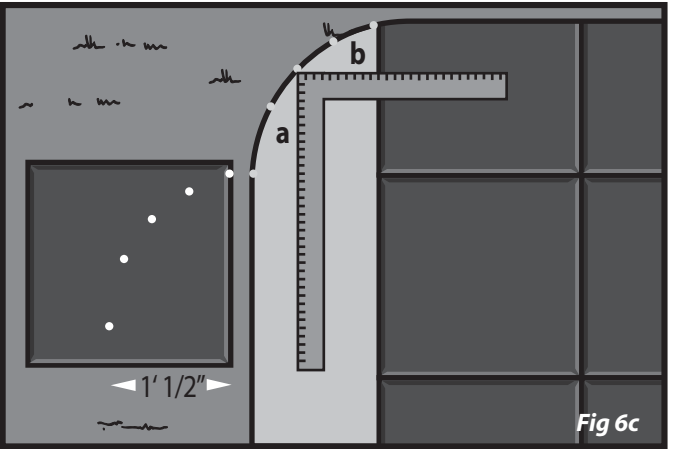

3. After the measurements have been transferred onto the tile to be cut, connect the markings using a flexible aluminum straight edge and felt tip marker (*Fig 6d*).

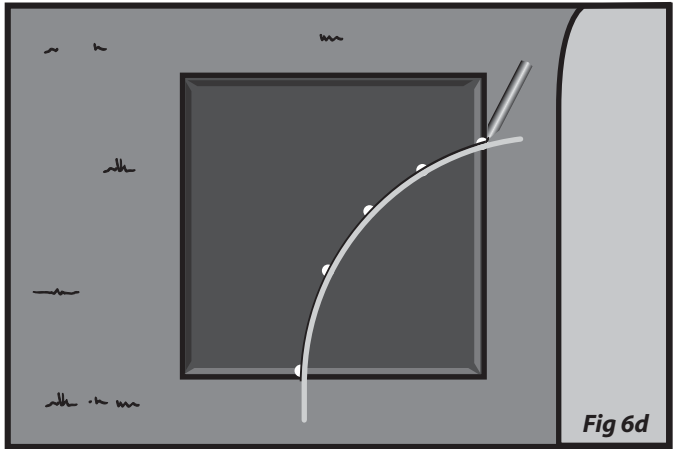

4. Continue measuring and marking all perimeter tile pieces.

Note: In the event that a full tile is placed against a retainer, it will be necessary to remove the “female” lock to allow the tile to fit flush. Once the lock is removed it is recommended that the cut piece is placed under the “male” lock to provide additional support.

When the tile is placed on the edge of a site or area and no ramps are added, the lock will be cut off. The lock, when removed, is to be reversed and installed on the same side of the tile under and in the lock location for added support. See ‘Cross-section and Overhead View’ below.

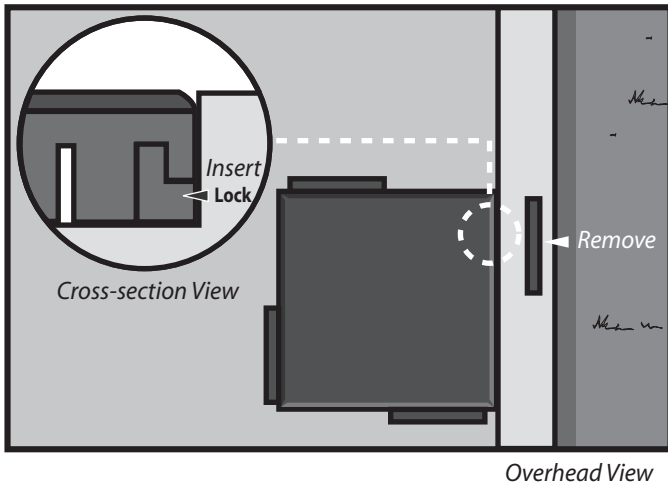

Marking Posts

Note: The diameter of playground equipment posts vary across the industry. If you are unsure of the diameter of your equipment post you can calculate it by measuring the circumference of the post and multiplying by .31831.

It is imperative that tile are in their correct position and fit together tight and lines are straight before tile measuring and cutting begins. Measure from the “key line”.

1. Determine the diameter of your posts and use a purchased template or make a template out of a hard material such as cardboard or plywood. A five inch diameter post would require a 5 inch or smaller circle for a template. A 4-3/4 inch or 4-7/8 inch template would help in obtaining a smaller circle and a tighter finish to the pole.

A 2 foot square and a silver felt tip marker work well to mark tile for cutting, the square allows you to make a small mark in the correct position/location. Do not make large long lines that will be exposed after cutting, try to pinpoint your marks, or at least keep marks as small as possible. **Measure twice to make sure you have measured correctly.** When marking tile or cutting tile always remember to make the cut an 1/8 to a 1/4 inch closer to the pole or edge surface to ensure a tight fit.

2. For easy visual reference place the tile to be cut near to and in a similar orientation to it’s final placement position (Fig 7a). When posts are located on a seam, place two tile joined together.

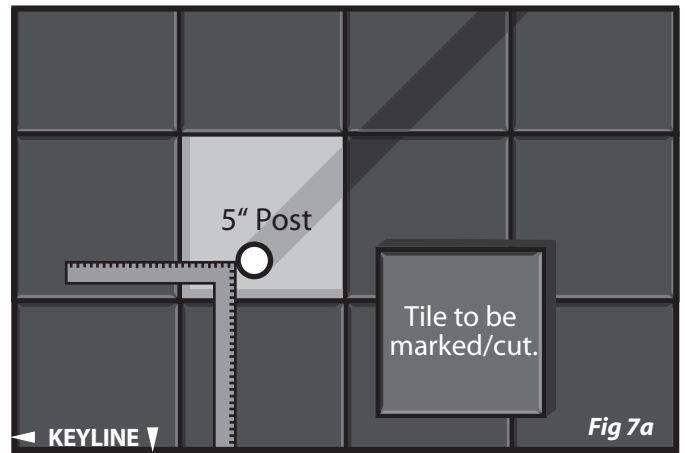

3. Using the square you will be taking two measurements. Measure the exact distance of the void between the edge of the post and the edge of the adjacent placed tile (Fig 7b). Also measure the approx. distance from the center of the post where the previous measurement was taken to the edge of the adjacent placed tile.

If the mark is made 1/8” to 1/4” smaller than the post the marks and lines can be cut off when you are cutting.

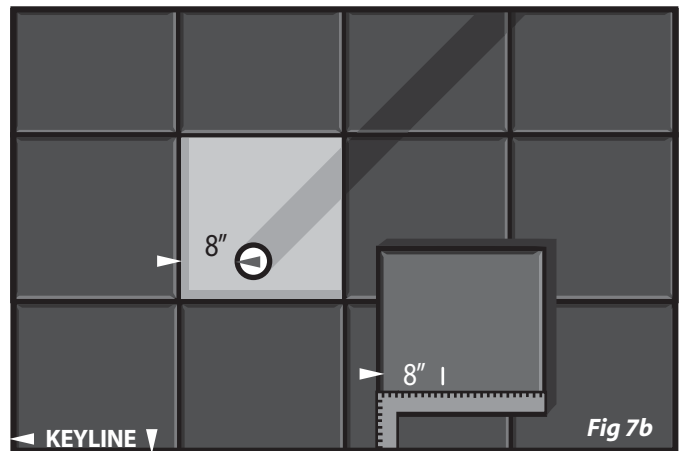

4. Center the square at the location where your two measurements meet. Transfer these measurements onto the tile to be cut by marking the tile. The marking should be in the form of a line as small as possible, but still visible (Fig 7c).

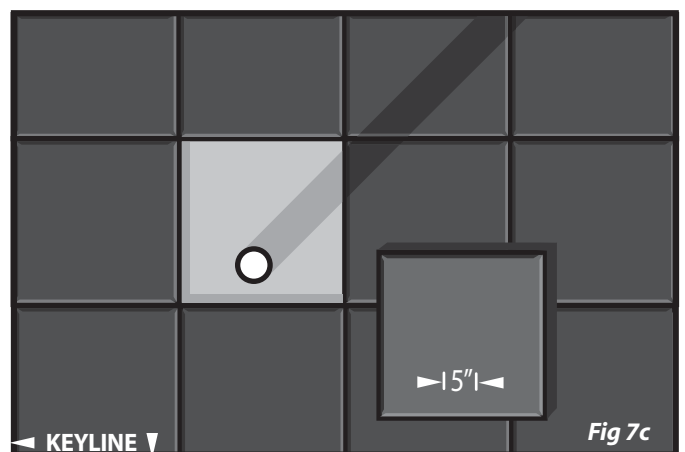

5. Once the first mark has been made a second mark can be placed based on the diameter of the post. Assuming a 5 inch diameter post, measure 5 inches across from the first post and place your second marking. You now have the first two reference points for the cut (Fig 7c).

6. Using the square you will be taking two new measurements. Measure the exact distance of the void between the edge of the post and the edge of the adjacent placed tile (Fig 7d). Also measure the approx. distance from the center of the post where the previous measurement was taken to the edge of the adjacent placed tile.

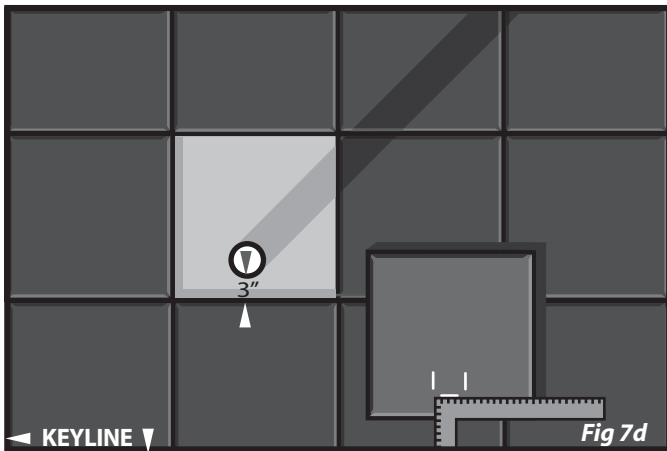

7. Center the square at the second location where your two measurements meet. Transfer the measurement onto the tile to be cut by marking the tile. The marking should be in the form of a line as small as possible, but still visible (Fig 7d).

8. Assuming a 5 inch post measure from your mark 5 inches across and place your final mark (Fig 7e).

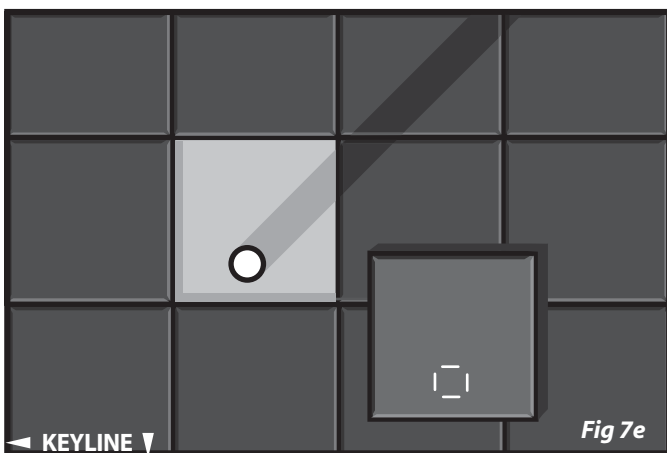

9. You now have four markings that resemble the outline of a square.

10. Place your template into the center of the "square" and mark the perimeter of the template. You are now ready to make your cut (Fig 7f).

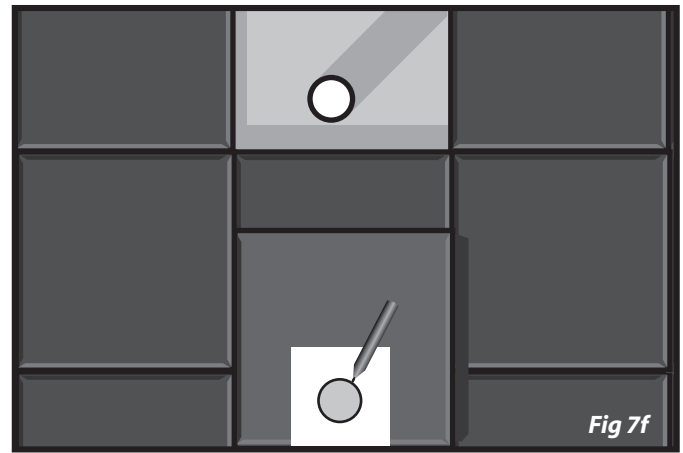

Note: You will need to cut into the side of the tile before you make your circular post cut. When doing so you will typically cut the side of the tile that represents the shortest distance from the tile edge to the cut (Fig 7g). Sometimes, however, you may wish to hide this joint or place this joint out of a heavy traffic area. The line should be made in a position that is between the pedestals.

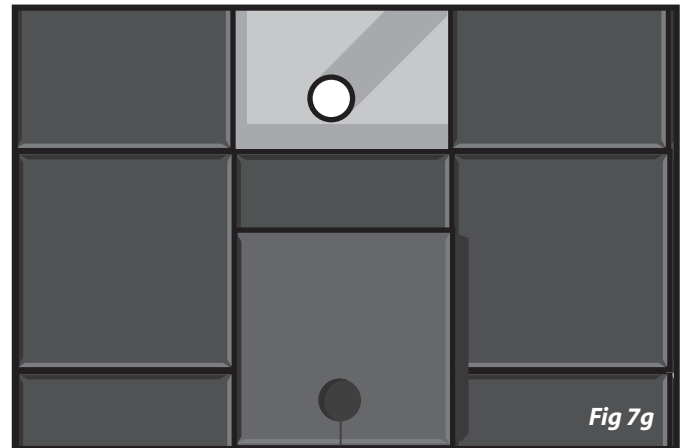

Cutting Tiles

The utility knife is used for straight cuts and the jigsaw is used for straight and irregular cuts. Never start your cut with the jigsaw blade that has teeth, always use your Olfa LA-X (or equivalent) utility knife to make the initial cut from edge of tile to edge of post cut. Use a straight edge or square for straight cuts with the knife. When using a jigsaw for cutting use a 15 to 20 degree back angle on the tile (Fig 7h on following page).

Place tile on a flat, level and hard surface. It can remain exactly where you have been measuring as long as precautions are taken so the tile beneath are not damaged. When using a jigsaw, ensure that the blade is a 1/4 - 1/2 inch shorter than the thickness of the tile when the jigsaw is in the extended position.

When cutting with the Olfa utility knife score the area to be cut first. Once a score has been made, apply pressure to the tile to

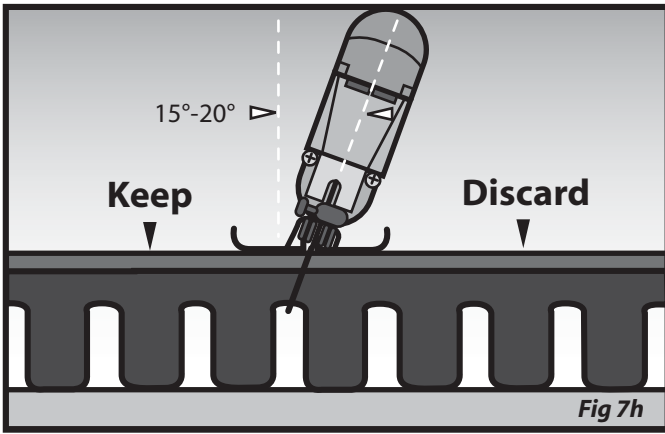

open the score. Placing the tile over a short 2X4 will help open up the scored section for cutting with the knife. Opening the score of the tile reduces friction between the tile and the knife making the cut much easier. Continue making passes with the knife working your way through the tile.

a) Cut Hole Smaller or Tile Larger

Since rubber is flexible and has the ability to compress it is always better to make your post hole cut a fraction smaller than required. This will allow for a very tight fit.

Making the posts cut on an inward 15 to 20 degree angle allows for a tight neat appearance and provides some additional flexibility (Fig 7h).

A simple reminder, that it's easier to do 2 cuts than trying to "stretch" a short piece!

b) Installing Cut Tiles

Always install the cut tile to ensure a proper fit prior to trimming pedestals / feet for surface mount plates and nuts. If your initial post cut is not acceptable, it saves valuable time if you do not trim pedestals twice. Recommend installing all post cuts before going back and trimming pedestals.

It is sometimes necessary to cut or trim the stanchions when cutting the tile to size. This will often create a soft area due to the lack of support. Expanding foam, (Great Stuff Window and Door) can be injected to fill the void.

REMEMBER - If in doubt, measure twice, cut once!

Adhering Tiles

No doubt SofTILE® unique locking design was one of the factors involved in your decision to purchase a KrosLOCK safety surface. In order to maximize this unique feature it is important to understand that our Locking system was engineered to be most effective when used with the proper quantity and placement of adhesive.

Prior to beginning the adhesive application process, the following checklist should be verified. Any corrections that need to be made will be much easier prior to the application of adhesive.

Before Adhering Tile – Checklist

- **Layout and design okay.** Check your layout and the drawings to ensure that your installation represents the intended design.
- **Straight lines and seams tight and aligned.** Make sure that all of your rows are straight and that all of the seams are properly aligned and tight.
- **No undulations.** Correct any undulations in the surface.
- **Cuts are tight and neat.** Make sure your perimeter and post cuts are tight and neat.

- **Sub surface dry and clean.** If gluing to the base verify that the sub surface is clean and dry. Dirt and moisture is the single greatest cause of bonding failure.

Adhesive Facts

- **A power adhesive dispenser complete with the specially designed tip is required for your installation. This will help in ensuring that the adhesive is placed in the proper location and in the correct amounts.**
- **Optimum temperature for substrate and sealant is between 60°F (15°C) and 75°F (25°C)**
- **Adhesive cures by reaction with atmospheric moisture. At low temperatures the water content of the air is generally lower and the curing reaction proceeds somewhat slower. Therefore cure rates are dependent on temperature and humidity.**
- **Adhesive is workable up to 30 minutes**
- **A 20 oz sausage tube of adhesive bonds approximately 36-40 lineal feet of tile edging**
- **A 2mm bead cures in approximately 16-24 hours at 75°F (25°C) and 50% relative humidity**
- **Adhesive requires 5 days curing at 75°F (25°C) prior to submersion under water.**

Key Points

- Only use adhesive provided by or recommended by the manufacturer.
- Adhesive comes ready to use. Do not open sausage tubes until preparatory work has been completed.
- Proper application of adhesive to the KrosLOCK joint is critical to the overall performance of your new safety surface.
- **Using too little adhesive, or applying the adhesive in the incorrect location can result in failure of the locking system.**
- **Sealing the entire length of the seam will prevent damage caused by the migration of sand and other loose particles into the seams of the product.**
- Surfaces must be clean and completely free of moisture.
- Surface temperatures above 40°F (5°C) degrees and rising are recommended.
- Avoid adhesive applications below 40°F (5°C) and above 105°F (40°C).
- Protective gloves should be worn to prevent skin contact.
- Tiles are not typically glued to the sub-surface, except for at the edge of site or in strategic locations.

Preparing the Equipment

In order to minimize any potential mess during adhesive application, a small set up area should be created using a piece of cardboard or other disposable covering material. Prior to beginning the adhesive application process, make sure you have rubber gloves; plenty of rags, utility knife and Methyl Acetone (MEK), Acetone or other suitable solvents for clean up purposes.

Whether a manual dispensing gun or a battery operated unit is used, the adhesive application procedure is very similar.

1. Open the dispensing unit by unscrewing the tip.
2. Pull the notched dispensing arm out to accommodate the adhesive tube.
3. When inserting the adhesive tube leave 3-4 inches exposed.
4. Using your knife cut the entire tip off the tube, and discard the end.
5. Hold the dispensing unit upright to allow the tube to slide entirely into the unit.
6. Ensure the nozzle and nozzle adaptor sections are tightly screwed into each other and then attach to the dispensing unit
7. If you are unsure of the initial dispensing flow you may consider doing some trial runs to get a feel for the appropriate speed you must travel, as well as how much pressure to apply in achieving 36 - 40 lineal feet per tube.

Application Methods

Adhesive application methods vary slightly depending on the type of installation and the substrate that the system will be placed on.

Regardless of the substrate used, all SofTILE® systems have minimum adhesive application requirements. Specific application instructions for tile-to-tile adhesion will be addressed later in this section.

Tile to tile adhesive is properly placed on the vertical wall of the interlocking joint and not in the bottom of the u-shaped locking system. Placing the correct amount of adhesive onto the proper location of the product will ensure the long term success of the installation (Fig 8a).

It is advantageous to start with the gluing of the perimeter tile to the base first. This will ensure that the tile surface will remain tight.

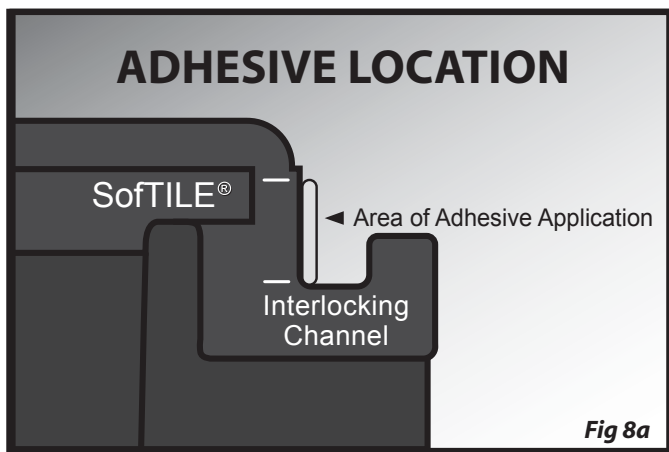

Perimeter to Retaining Wall

For edge and base adhesion which is recommended for outdoor applications. When a retaining wall is used around the perimeter of the site, adhesive must be placed between the edge of the perimeter tile and the retainer.

a) Outdoor Installation to Curb

In order to ensure adhesive contact between the tiles and a curb, it is imperative that an adhesive is applied between the edge of the tile and the retaining wall or curb. Because a tile has typically been cut vertically along the pedestals, the addition of polyurethane foam is required to ensure both support and adhesion (Fig 8b).

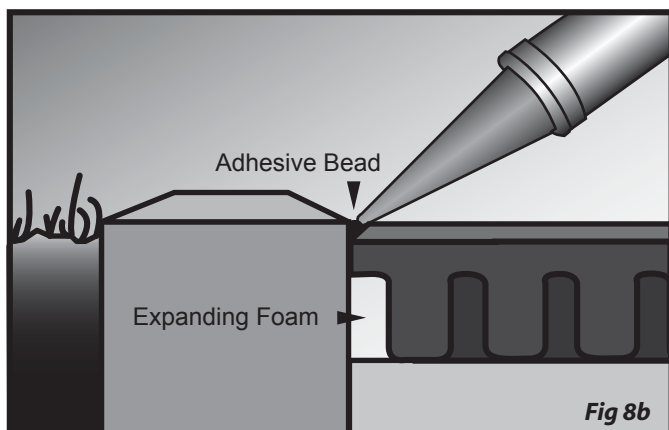

b) Outdoor Installation with Concrete or Asphalt Substrate

- Adhere to Base

Perimeter tile adhesion is done by either turning the tile over, and applying a 1/2" diameter bead of adhesive around each circular pedestal on the first half of each perimeter tile (Fig 8c) or by applying the adhesive to the first 12" of the perimeter sub-surface using a 3/8" notched trowel (Fig 8d).

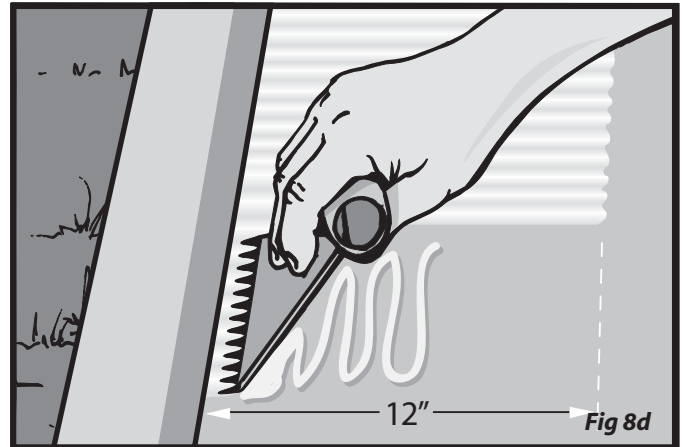
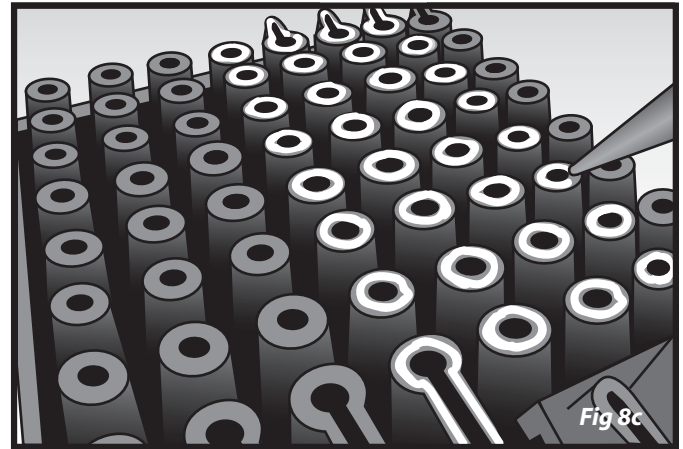

c) Outdoor Installation of Edge Tile -

- Insufficient Support of Pedestals

It is sometimes necessary to cut or trim the pedestals when cutting the tile to size. This will often create a soft area due to the lack of support. Polyurethane expanding foam can be injected to fill the void and provide stability at the edge of the site. A final bead of adhesive would then be applied where the tile and retaining wall meet (Fig 8b).

Perimeter with SofRAMP®

Installation of ramps should be completed during the cooler part of the day.

When a SofRAMP® transitional edge piece is used, adhesive should be placed both between the tile and SofRAMP® and to the underside of the SofRAMP® to secure it to the subsurface. This is achieved by placing three or four 1/2 inch beads of adhesive to the underside of the SofRAMP® transitional edge.

When a SofRAMP transitional edge piece is used, and the tile is higher than 3.5 inches, a 'firing strip' is typically included with your shipment. The firing strip is added for stability under the lock (Fig 8e).

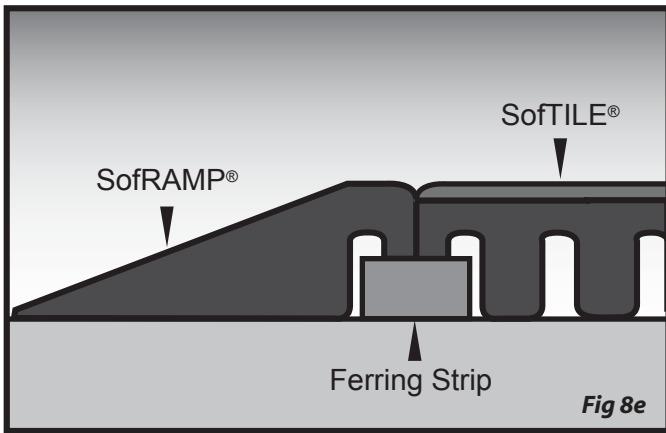

Prior to the installation of ramps, be sure to kick the tiles and perimeter tight. After applying the adhesive, ensure that the ramps are kicked tightly into the tile field. A tight fit is critical.

Perimeter to Topsoil/Sod

When the site edging will be an open tile and the surrounding back filled with topsoil and sod - cut the exposed male locking section and glue it into the female locking section thus creating a stable edge and minimizing the likelihood of the migration of topsoil, grass and other debris under the tile surface.

Playground Post Cuts

Adhesive should be applied in the cut from tile edge to post hole.

Application Nozzles

You will notice that the adhesive application tip has been custom designed for use with the KrosLOCK system. See Fig 8f showing tip in relation to tile. The tip has been designed to control both the depth and placement of the adhesive. Although the tip has been designed to minimize seepage, careful attention must be paid to ensure that the correct amount of adhesive is being applied. Too little adhesive will affect the performance of the locking system. Too much adhesive will result in overflow requiring removal of the excess adhesive the following day.

Custom supplied tips have a steel depth guide which will interfere with adhesion around the perimeter of the site as well as around the play ground equipment posts. Adhesive application in these areas will require the use of the standard plastic cone tips supplied with the order (Fig 8f).

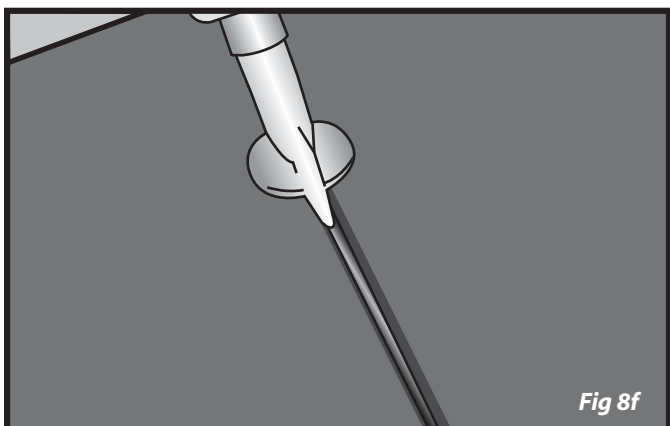

Adhesive Application Techniques

Insert the custom applicator tip into the seam of the tiles until the depth guide is flush with the top of the tiles.

Begin applying the adhesive between the tiles ensuring that the appropriate amount of adhesive is being applied to each tile. If adhesive begins to seep from the seams of the product adjustments will need to be made to your pressure and speed.

Heating the adhesive prior to use ensures proper and consistent flow rates and ease of application, especially during cooler temperatures. It is recommended that the adhesive be heated to a minimum of 75 degrees.

The ideal quantity of adhesive will provide sufficient contact to both sides of the tile and will rise to within 1/16 of an inch from the top surface. Using the power gun and setting the gun at setting 2.1 it takes 5 seconds for a 2 foot tile seam, to apply sufficient adhesive.

Each sausage tube contains approximately 36 to 40 lineal feet of material.

Because the adhesive is a moisture cure sealant, the sealant can be lightly misted with water when installed in arid climates or when you wish to accelerate the cure rate. A garden sprayer can be used for this purpose.

Any excess adhesive should be left to fully cure (approx 24 hrs) prior to removal the following day. The excess adhesive can be quickly and neatly removed using a sharp razor knife.

Key Points

- When removing the tip from the seam be sure to have a rag available.
- Apply adhesive to an entire row at a time keeping track of the rows you have completed or where you have stopped – use a chalk mark, golf ball marker, flag, etc.
- To prevent blockage at the corners of each tile by cured adhesive, the application should take place in both directions representing the length and width of the site within 30 minutes of each other. For larger sites it may be more efficient to glue in quadrants.
- **Under no circumstances should a SofTILE® system be installed outdoors without the use of adhesive.**

Summary

- Proper application and quantity of adhesive to the KrosLOCK joint is critical to the overall performance of the surfacing system.
- Only use adhesive provided by or recommended by the manufacturer.
- Protective gloves should be worn to prevent skin contact.
- Take caution to ensure that adhesive is not spilled on adjacent surfaces.
- Uncured adhesive spills can be removed with a rag and Methyl Acetone (MEK), Acetone or other suitable solvents.
- Cured adhesive can only be removed by mechanical means.
- To clean your tips use a small folded piece of paper or “q-tip” and solvent such as Sika Remover 208, Methyl Acetone (MEK), Acetone or other suitable solvents.

Mistakes/Repairs, after installation of adhesive can be easily corrected if you allow the adhesive to cure "one day" you can cut the adhesive along the seam, easily remove and replace any tile that may require further attention.

Final Installation Details

1. Remove any Adhesive Spills

a) "Smearred" Adhesive Spill – Try not to smear further.

If a small amount of adhesive is spilled onto the surface during installation, this can be removed immediately by wiping the spot with a rag containing a small amount of Methyl Acetone (MEK), Acetone or other suitable solvents. Use proper handling procedures. Try to “lift” the adhesive if possible from the surface.

b) "Bead-Shaped" Adhesive Spill

If any adhesive inadvertently drips out of the end of the caulking tube onto the SofTILE® surface, and this adhesive lies on the tile in a convex shaped bead, with extreme caution it can be lifted immediately (do not smear) with a cloth or knife. If unable to lift it should be removed only after it has partially cured. Area will need to be protected so the area is not walked on. After curing you will need to use a knife to “scrape” the bead off of the tile.

2. Initial Appearance and Maintenance

Solid SofTILE® colors will behave like new carpets when initially installed. The solid, brilliant colors will make the initial dust created by foot traffic very apparent. However, with time, the visible dust tracking will diminish.

3. Initial Odor

The polyurethane used to bind the rubber granules is 100% inert and odorless after it has fully cured. Full curing can take up to several days depending on atmospheric temperature and moisture. The odor may take longer to dissipate on indoor applications because of the confined area. The rubber may also have an odor.

4. Sealant

It is SofSURFACES® recommendation not to apply sealants to any SofTILE® surface. However should you have any questions about sealing or coating the surface of the SofTILE® product please contact our office.

Routine Maintenance

1. Routine Maintenance Extends Life and Enhances Appearance

Like any surface, a good routine maintenance program will enhance the longevity and appearance of the SofTILE® surface.

2. Sweeping

Sweeping the surface with a broom will be the most common method of keeping the SofTILE® surface clean. However, because of the porosity and granular texture of the surface, it is difficult to remove all contaminants by sweeping alone.

3. Vacuum

Periodic vacuuming is recommended in areas where sand is frequently tracked onto the surface.

4. Water Hose

Use a water hose with a pressure spray tip to remove contaminants from porous top surface. This is easier than using a broom. However, interior installations may place restrictions on water usage.

5. Cleaning Agents

SofTILE® can accommodate moderate use of most household or commercial cleaners that contain both odor suppressants and disinfectants. Dilute this cleaning agent as recommended by the manufacturer. Apply to the surface using a mop or scrubbing device. This will remove most light stains.

Advanced Maintenance

Depending on frequency of use, SofTILE® will occasionally need a “deep clean” to remove built up dirt and stains.

1. Steam Vacuum

A steam vacuum with or without cleaning agents is ideal for advanced cleaning and maintenance. Follow instructions.

2. Power Washing

In areas that can accommodate power washing, use a power washer with a wand tip.

The entire SofSURFACES® team wishes to thank you for your careful consideration and decision to purchase a SofTILE® safety surfacing system. Your investment in a SofTILE® system is a wise one. The locking feature found in our KrosLOCK design will not only make your installation simpler but it will enhance the appearance, strength and durability of your safety surface for years to come.

It is important to note that proper installation is a critical component to the overall success of your surface and this manual has been prepared with the long-term performance of your surface in mind. By carefully following the procedures set forth in this manual, you can be assured of a quality installation.

We work hard to produce the highest quality products and our dedication to customer service does not end with the sale of our surfaces. As industry leaders we are committed to the long-term success of your project.

We are available by phone at 1-800-263-2363 from 8:00 am to 5:00 pm, Monday through Friday, EST.

Thank you for your confidence; it is a pleasure to know that our efforts have made your playground safer.

INSTALLATION INSPECTION FORM

Facility or Site Name: _____ Inspection Date/Time: _____

Address: _____

Installation Date(s) & Weather Conditions: _____

Installation Company: _____ Crew Leader: _____

- Include list of all installation team members on site
- Include photos of before and after shots
- Record temperatures and weather each day while on site

	Yes	No	COMMENTS
1. SUB SURFACE CONDITIONS			
Concrete Curbs	<input type="checkbox"/>	<input type="checkbox"/>	_____
Concrete Keyway Under Ramp and Tile	<input type="checkbox"/>	<input type="checkbox"/>	_____
Width of Keyway _____			_____
Concrete (preferred surface) Cured	<input type="checkbox"/>	<input type="checkbox"/>	_____
Old <input type="checkbox"/> New <input type="checkbox"/>			_____
Asphalt	<input type="checkbox"/>	<input type="checkbox"/>	_____
Old <input type="checkbox"/> New <input type="checkbox"/> 12 Inch Concrete Keyway <input type="checkbox"/>			_____
Ground Off Surface to Granular <input type="checkbox"/>			_____
2. SITE CONDITIONS - General			
Cleanliness of Site	<input type="checkbox"/>	<input type="checkbox"/>	_____
Damage	<input type="checkbox"/>	<input type="checkbox"/>	_____
Vandalism	<input type="checkbox"/>	<input type="checkbox"/>	_____
3. SITE CONDITIONS - Installation			
Surface is Level - No Undulations	<input type="checkbox"/>	<input type="checkbox"/>	_____
Tiles and Joints are Straight	<input type="checkbox"/>	<input type="checkbox"/>	_____
Cuts Accurate and Tight			_____
Around Posts	<input type="checkbox"/>	<input type="checkbox"/>	_____
At Curbs	<input type="checkbox"/>	<input type="checkbox"/>	_____
4. ADHESIVE			
All Joints Adhered 100% - Level to Bevel	<input type="checkbox"/>	<input type="checkbox"/>	_____
All Edges and Cuts Adhered 100%	<input type="checkbox"/>	<input type="checkbox"/>	_____
Excessive Adhesive Removed	<input type="checkbox"/>	<input type="checkbox"/>	_____
5. SECURE SURFACES			
Edges Secure and Firm	<input type="checkbox"/>	<input type="checkbox"/>	_____
At Posts Secure and Firm	<input type="checkbox"/>	<input type="checkbox"/>	_____
Ramp Secure	<input type="checkbox"/>	<input type="checkbox"/>	_____

I hereby certify that the above areas are either in good working condition or deficiencies have been forwarded to the appropriate office.

Site Inspector: _____
Print Name

Signature

Site Installer: _____
Print Name

Signature

INSTALLATION INSPECTION FORM

Facility or Site Name: _____ Inspection Date/Time: _____

Address: _____

Installation Date(s) & Weather Conditions: _____

Installation Company: _____ Crew Leader: _____

- Include list of all installation team members on site
- Include photos of before and after shots
- Record temperatures and weather each day while on site

1. SUB SURFACE CONDITIONS	Yes	No	COMMENTS
Concrete Curbs	<input type="checkbox"/>	<input type="checkbox"/>	_____
Concrete Keyway Under Ramp and Tile	<input type="checkbox"/>	<input type="checkbox"/>	_____
Width of Keyway _____			_____
Concrete (preferred surface) Cured	<input type="checkbox"/>	<input type="checkbox"/>	_____
Old <input type="checkbox"/> New <input type="checkbox"/>			_____
Asphalt	<input type="checkbox"/>	<input type="checkbox"/>	_____
Old <input type="checkbox"/> New <input type="checkbox"/> 12 Inch Concrete Keyway <input type="checkbox"/>			_____
Ground Off Surface to Granular <input type="checkbox"/>			_____
2. SITE CONDITIONS - General			
Cleanliness of Site	<input type="checkbox"/>	<input type="checkbox"/>	_____
Damage	<input type="checkbox"/>	<input type="checkbox"/>	_____
Vandalism	<input type="checkbox"/>	<input type="checkbox"/>	_____
3. SITE CONDITIONS - Installation			
Surface is Level - No Undulations	<input type="checkbox"/>	<input type="checkbox"/>	_____
Tiles and Joints are Straight	<input type="checkbox"/>	<input type="checkbox"/>	_____
Cuts Accurate and Tight			_____
Around Posts	<input type="checkbox"/>	<input type="checkbox"/>	_____
At Curbs	<input type="checkbox"/>	<input type="checkbox"/>	_____
4. ADHESIVE			
All Joints Adhered 100% - Level to Bevel	<input type="checkbox"/>	<input type="checkbox"/>	_____
All Edges and Cuts Adhered 100%	<input type="checkbox"/>	<input type="checkbox"/>	_____
Excessive Adhesive Removed	<input type="checkbox"/>	<input type="checkbox"/>	_____
5. SECURE SURFACES			
Edges Secure and Firm	<input type="checkbox"/>	<input type="checkbox"/>	_____
At Posts Secure and Firm	<input type="checkbox"/>	<input type="checkbox"/>	_____
Ramp Secure	<input type="checkbox"/>	<input type="checkbox"/>	_____

I hereby certify that the above areas are either in good working condition or deficiencies have been forwarded to the appropriate office.

Site Inspector: _____
Print Name

Signature

Site Installer: _____
Print Name

Signature

